

| Parts List | | | | |
|------------|-----|----------|-------------------------------|---|
| ITEM | QTY | PART No. | TITLE | WebLink |
| 1 | 1 | BB9046 | USB-A 50W Secondary Test Unit | http://e-sea.bluelogic.no/main.aspx?page=article&artno=BA6047 |
| 2 | 1 | BB8896 | Cable RS232/RS485 | N/A |
| 3 | 1 | BB8895 | Power Cable Sec Side | N/A |

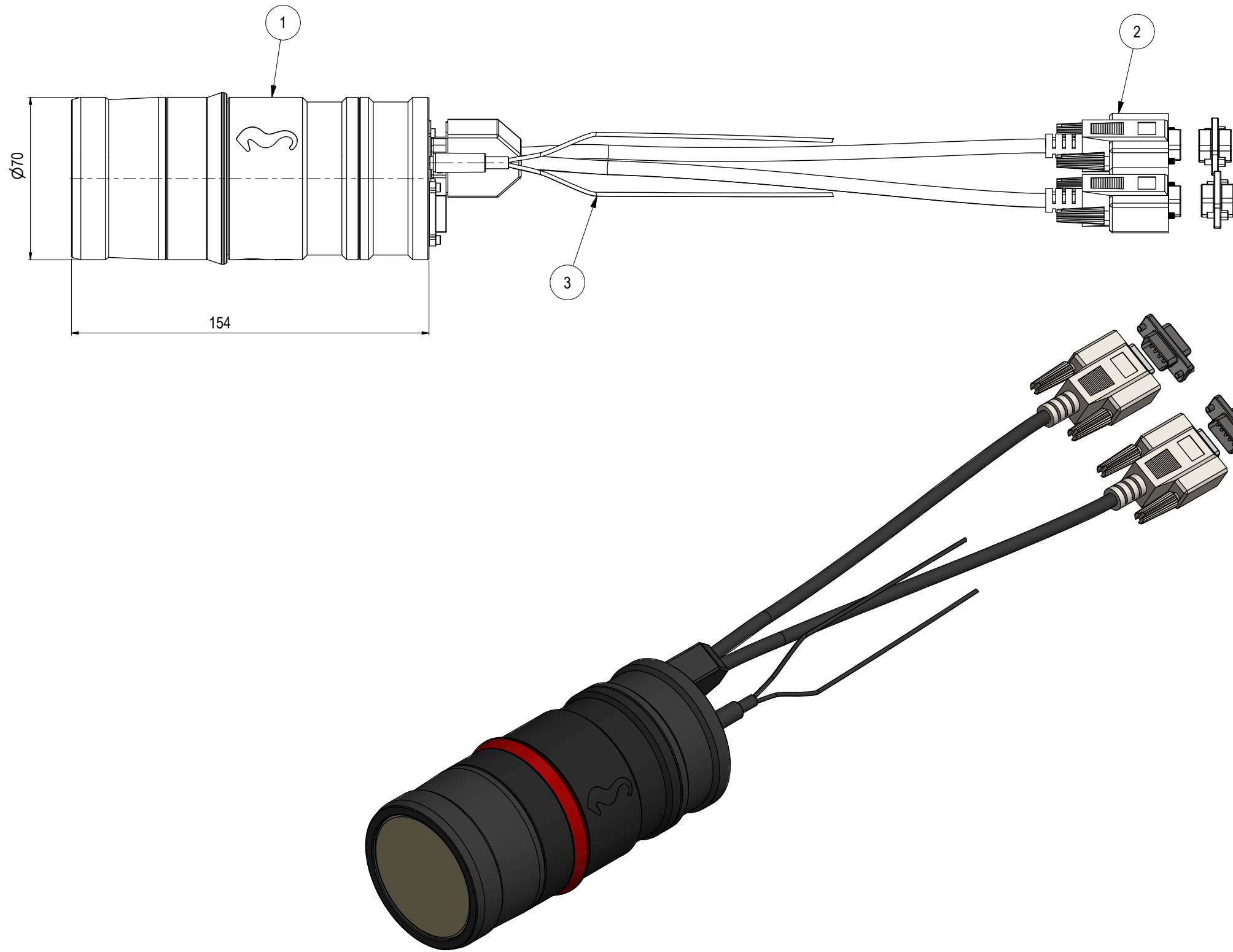

NOTE: 1
DESIGN CODE:
N/A

NOTE: 2
TECHNICAL CLASSIFICATION:
Article Type: 006-EI. Connectors
Main Group: 6.01. Subsea USB
Intermediate Group: 18.190.01. USB-A
Sub Group: 6.28.95.01. Male Connector

NOTE: 3
INTERFACE INFORMATION:
Pressure Rating Bar: N/A
Design Water Depth: N/A
Material: N/A
Weight: 0,6 kg
Volume: 0,43 dm³
Submerged Weight: 0,19 kg
Surface Area: 2640 cm²
Hydraulic: N/A
Mechanical: N/A
Electrical: N/A
Com. & Protocol: N/A

NOTE: 4
OPERATION & MAINTENANCE INFORMATION:
600128-TD-0020

NOTE: 5
ADDITIONAL INFORMATION:
Power cable for BB2332, Secondary Side Test Connector. Complete with DC power plug for connection to Test Connector. Cable consists of 2 separate AWG18 cables with pigtail to suit any connection to power supply. Total cable length 3m.

Communication cable for BB2332, Secondary Side Test Connector. Complete with D-Sub connector for connection to Test Connector. Two separate cables with female socket connector of type DE-9 for RS232 and RS485 communication. Total cable length 3m.

| | | | | | | |
|------|------------|------------------------|-----------------|------|-------|-------|
| 09 | 5.7.2023 | 9-IFU (Issued for Use) | | WTJ | ERO | WTJ |
| 08 | 25.4.2023 | 9-IFU (Issued for Use) | | WTJ | RAN | TGU |
| 07 | 1.12.2022 | 9-IFU (Issued for Use) | | WTJ | LGH | WTJ |
| 06 | 19.10.2022 | 9-IFU (Issued for Use) | | WTJ | SEA | WTJ |
| Rev. | Date | Reason for issue | Revision change | Made | Chk'd | Appr. |



| | |
|-------------|-----|
| Dwg Scale: | NTS |
| Dwg Proj: | |
| Dwg Format: | A3 |

| | | |
|-----------------|---------------------------------------|---------|
| Drawing title: | USB-A 50W Secondary Test Unit wCables | |
| Drawing number: | BB2332 | Rev. 09 |